

For impressive entrances
For high quality solutions
For many applications

BW BLUE WEST
GmbH



BW-03090

Hotel locks

THE ELECTRONIC LOCK WITH
THE BEST QUALITY/PRICE
RATIO ON THE MARKET.

SMART HOTEL SOLUTIONS

Content

Product introduction	2
Innovations	3
Features & Standards	4
Finishes available options	5



BW-03090

Specially designed for Hotels, Offices and Residences, BW-03090 integrates all security features into a single reliable and efficient device.

The electronic proximity lock with the best quality/price ratio on the market.

Optional Bluetooth opening via app.

Blue west is in a constant process of R&D&I. As a result of all the work and experience applied to electronic locks, Blue west has developed the BW-03090 model of Mifare proximity electronic lock for hotel.

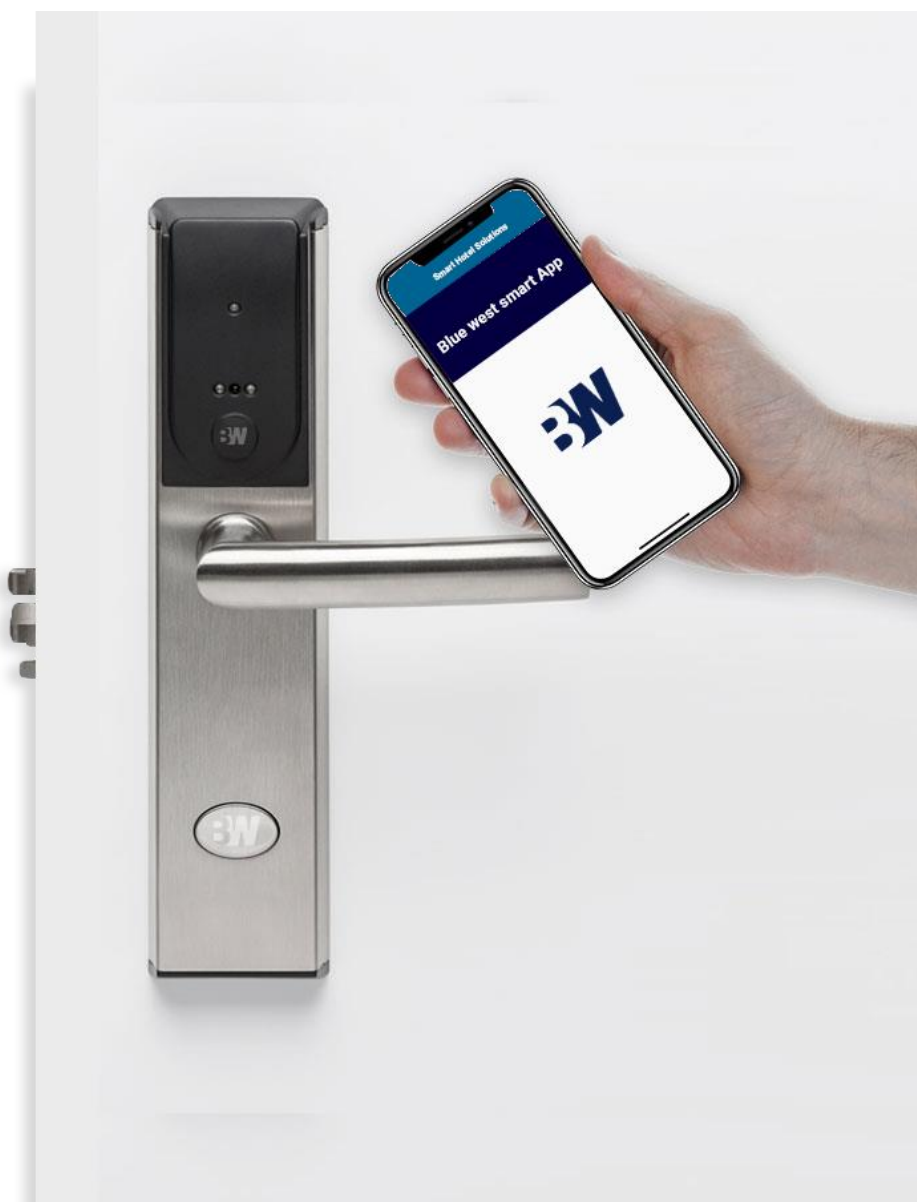

Innovations

Silent latch.

System of freely rotating lever in closed situation.

remote opening and management by including Gateways in the installation.

Anti-panic function, to guarantee emergency exits.

Anti-card device, to prevent undesired entries.



Features & Standards

- System of opening with MIFARE proximity 13.56 Mhz. Optional Bluetooth opening.
- Guaranteed operation in the most adverse climatological environments, thanks to its manufacture of stainless steel AISI 304 and its tropicalized electronics.
- Electronic lock with visual and acoustic indicators to facilitate their use by disabled persons, as well as for additional functionalities such as low battery warnings to personnel, privacy indicator, etc.
- Electromechanical privacy function with exterior visual indicator to prevent entries of unauthorized persons.
- Includes NON-volatile EPROM which even when batteries are changed, allows the conservation of the last 400 openings, with information of user, date and time.
- Equipped with real-time clock, which facilitates the management of any of the entries by personnel and guests.
- The BW-03090 electronic hotel lock has a hidden mechanical cylinder, for auditable emergency openings.
- Operates with 4 standard AA batteries with duration of up to 20,000 openings.
- Configuration and auditing of the locks with wireless control unit.
- Electronic lock Free Turn with EURO mechanics as standard. ANSI mechanics available with fixed handle.
- By installing Gateways, all devices equipped with Bluetooth become devices on-line, allowing remote management from the front desk pc or with a Smartphone.

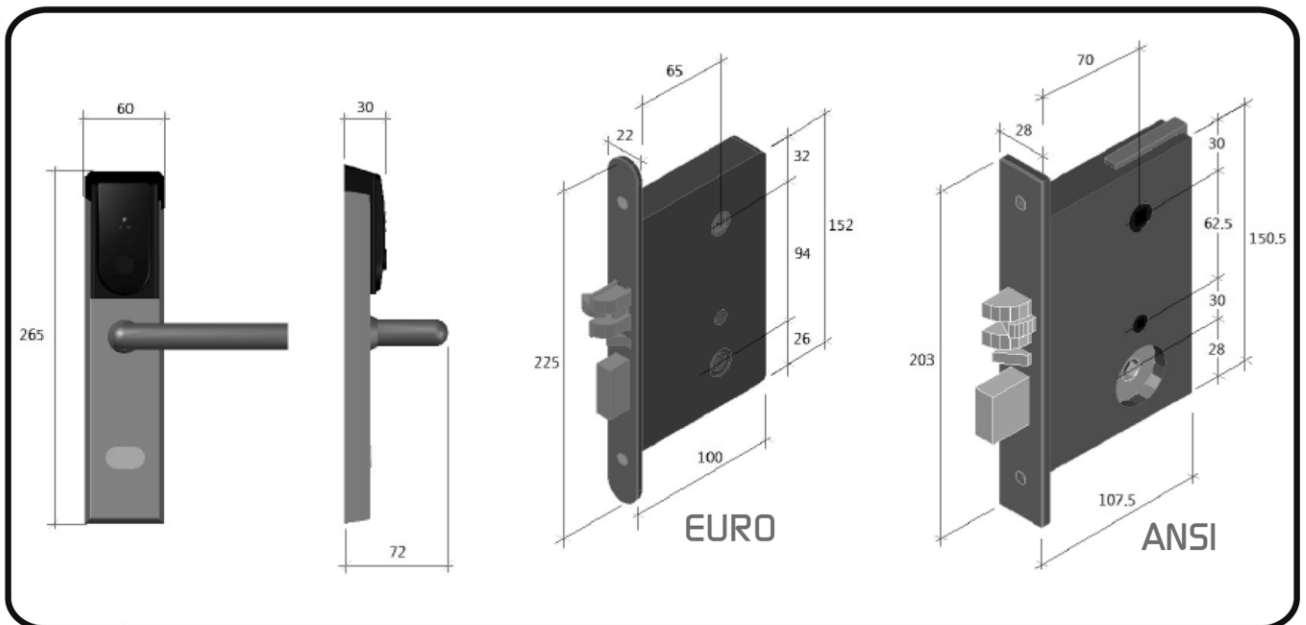

Finishes available options

Natural
Stainless Steel
AISI 304



BW-03090

Black
Stainless Steel
AISI 304



BW-03061S

Gold
Stainless Steel
AISI 304



BW-03062S

White
Stainless Steel
AISI 304

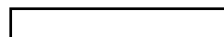

BW-03063S



FINISHES

INOX, BLACK EDITION
GOLD, WHITE, ANTI-BACTERIAL



STRENGTH

STAINLESS STEEL AISI 304 & 316



DIMENSIONS

60 x 265mm





Sale office

Maslak 1453, Ticari T4b blok -7kat Daire
153, Sarıyer-Istanbul
+90 850 305 930
info@bluwestmiddleeast.com



Neuer Wall 71 c/o WorkRepublic 20354
Hamburg - Germany
+49 (0) 40 9999 9442-9
www.bluwest.de
info@bluwest.de